

VPS9

IP 24c

Monteringsanvisning
Monteringsvejledning
Monteringsanvisning
Asennusohjeet
Montageanweisung

Installation instructions
Instrukcja montazu
Montavimo instrukcija
Инструкция по установке

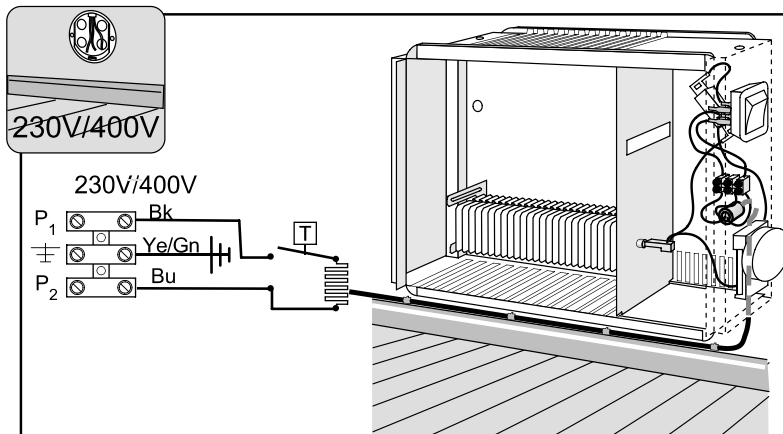
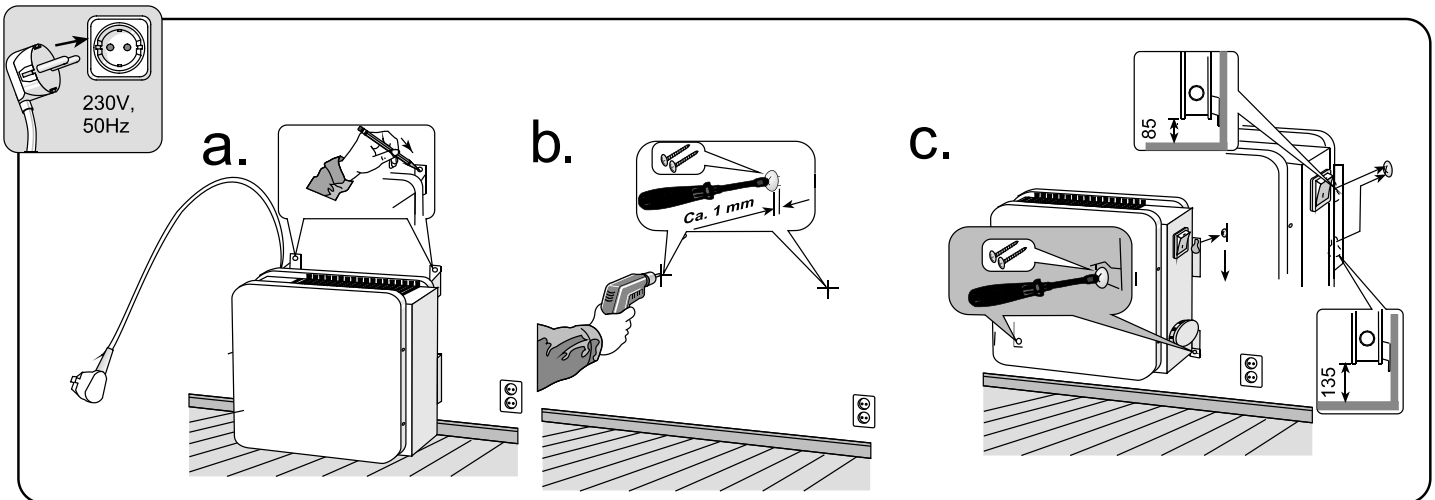
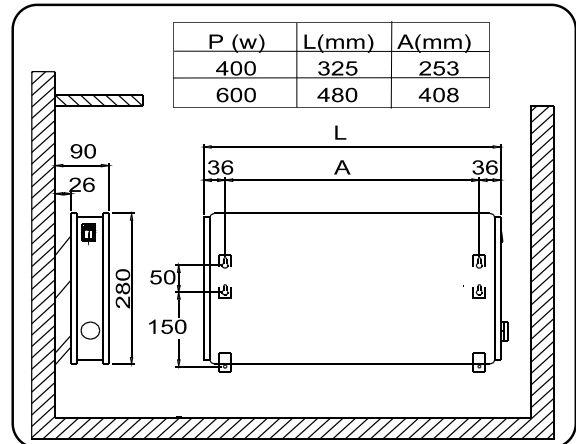
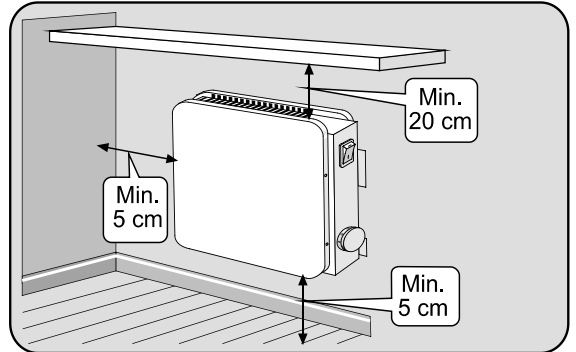
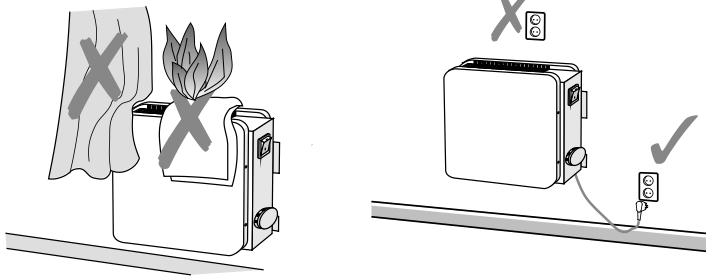
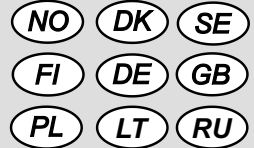

Elektrisk montasje må bare utføres av autorisert installatør.
Elektrisk montage må kun udføres af autoriseret el. installatør.
Elektrisk installation får endast utföras av behörig installatör.
Sähköasennukset saa suorittaa vain asennusoikeudet omaava asennusliike.
Anschluß darf nur durch Fachmann durchgeführt werden.
Electric installation must be carried out by an authorised electrician.
Podłączenie do sieci elektrycznej należy powierzyć elektrycy.
Instaliavimas ir pajungimas turi būti atliekamas sertifikuoto elektriko.
Установка должна быть произведена сертифицированным электриком.

**Brug
Brug
Användning
Käyttö
Bedienung
Use
Obsługa
Naudojimas
Использование**

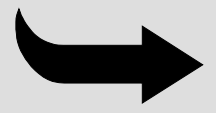

Art. nr. 62289 02/04

Ye/Gn	Gul/grønn	Gul/Grøn	Gul/Grøn	Kelta/Vihreä	Gelb/Grün	Yellow/Green	Zolty/Zielony	Geltonas/Žalias	Жёлтый/Зелёный
Bk	Sort	Sort	Svart	Musta	Schwarz	Black	Czarny	Juodas	Чёрный
Bu	Blå	Blå	Blå	Sininen	Blau	Blue	Niebieski	Mėlynas	Синий

VPS9

Bruksanvisning
Brugsanvisning
Bruksanvisning
Käyttöohjeet
Bedienungsanleitung

Instruction for use
Instrukcja obsługi
Naudojimosi instrukcija
Инструкция по использованию

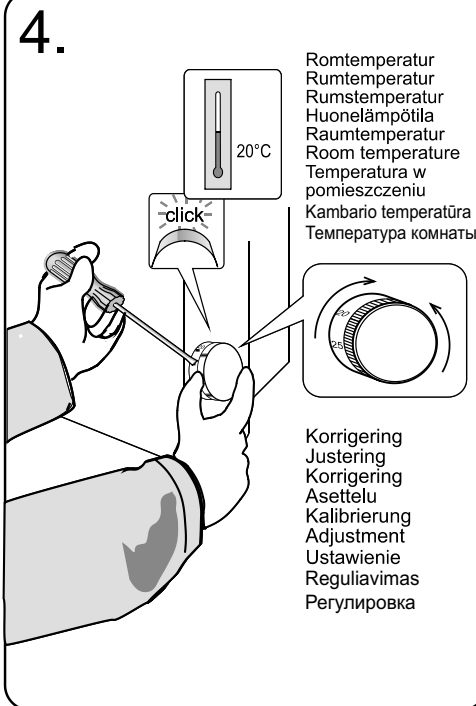
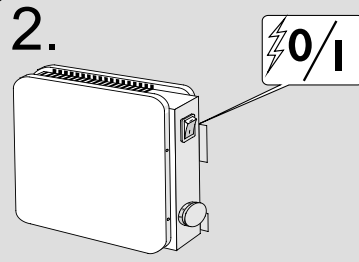
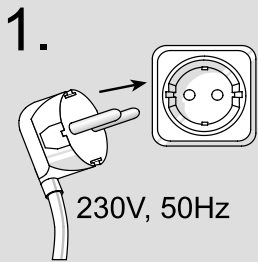
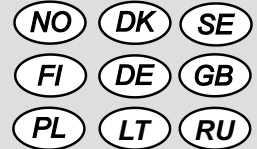

(NO)

Service: ADAX AS, 3060 SVELVIK, tlf. 33 771792.
NB! Ta vare på kvitteringen for dokumentasjon av kjøpsdato.

(DK)

Service: Appliance A/S, Korskildeeng 5, DK-2670 Greve Strand, tel. +45 43410060.
NB! Husk kvittering for købsdato.

(SE)

Service: El & Digital service AB, Ringvägen 17 S-10273 STOCKHOLM, tel. 08 845180.
OBS! Faktura/kvitto gäller som garantibevis.

(FI)

Huolto: Elektroskandia Oy, Varastokatu 9, 05800 HYVINKÄÄ, puh. 010 509311.
Aronen J & K Oy, Ostuuskunnantie 54A, 00660 Helsinki, puh. 09 724 7772.
Huom! Säilytä kuitti todistuksena ostopäivästä.

(DE)

Service: ADAX AS, NO-3060 SVELVIK, NORWEGEN, Tlf. +47 33 771792.
NB! Quittung zum Nachweis des Kaufdatums aufheben.

(GB)

Service: ADAX AS, NO-3060 SVELVIK, NORWAY, phone +47 33 771792.
NB! Retain the receipt as proof of date of purchase.

(PL)

Serwis: Elektra, ul. Marynarska 14, 02-674 Warszawa, tel. (+22) 8433282
Prosimy zachowac rachunek zakupu oraz karte gwarancyjna.

(LT)

Aptarnavimas: UAB Adax, Paliūniškio g. 7a, LT-35113 Panevėžys, Lietuva, tel.: +370 45 577929
DĖMESIO! - Saugokite kasos kvitą, kaip pirkimo datos įrodymą.

(UA)

Обслуговування: (8-044) 5500055

www.adax.no

ADAX

Montering
Montering
Montering
Asennus
Montage
Installation
Instalacja
Montavimas
Установка



Declaration of conformity

We declare under our sole responsibility that this product is in conformity with the following standards:
EN 60 335-1 (1988)+A2+A5+A6+A51+A52+A53+A54, EN 60 335-2-30 (1992), EN 55014 (1993), EN 60555-2/-3 (1991),
EN 50082-1 (1992) following the provisions of Directives 73/23/EEC, 93/68/EEC, 89/336/EEC.

Adax Fabrikker A/S, SVELVIK, NORWAY December 1996.

Tor Age Kverne