

Аксессуары

Тормозной прерыватель

Напряжение	400 В											
Модель	BRD-VZ3								BU			
Серия	370H		550H		750H	750H (x2)			160-4S	220-4S	160-4S (2)	220-4S (2)
Мощность преобразователя	30	37	45	55	75	90	110	132	160	220	280	350
Максимальное напряжение на звене постоянного тока	DC 800 В											
Пороговое напряжение срабатывания	725 ± 5 В											
Средний тормозной момент	130 %											
Доступный тормозной момент	20~30 %											

Встроенный тормозной прерыватель в преобразователе частоты до 22 кВт включительно.

Схема подключения

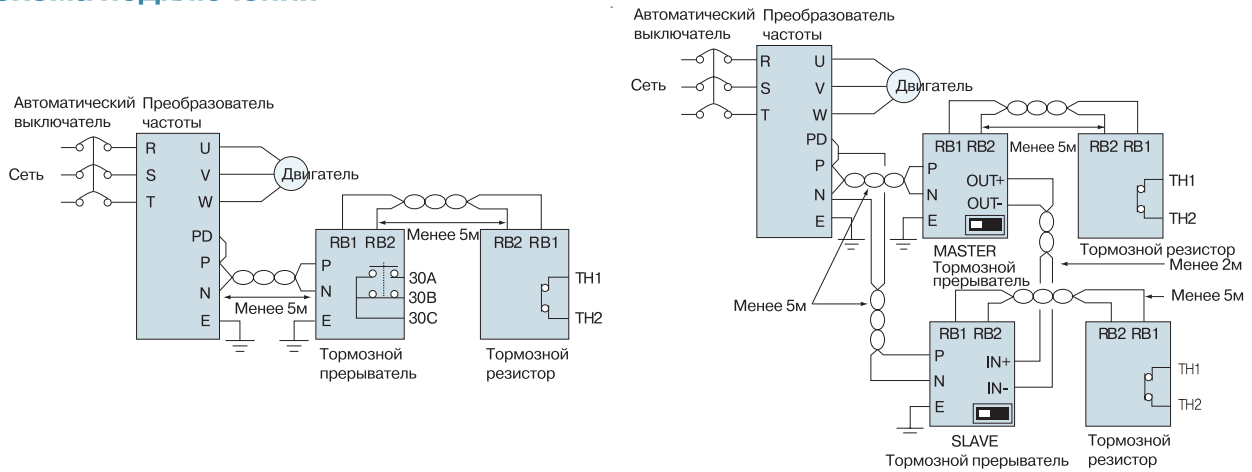

Мощность преобразователя до 75 кВт

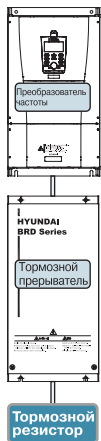

Мощность преобразователя 90-132 кВт

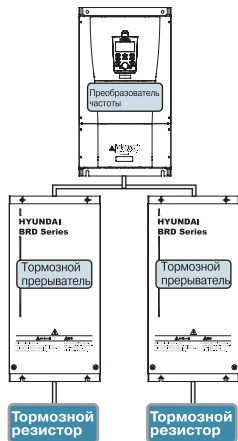

Габариты, мм

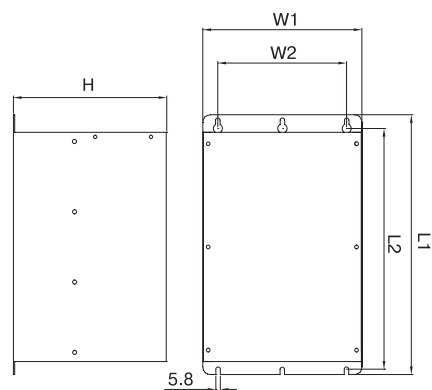

Модель	L1 ± 2	L2 ± 2	W1 ± 2	W2 ± 2	H ± 2
BRD-VZ3	285	274	140	100	166
FBUH160-4S	340	325	295	254	202
FBUH220-4S	340	325	381	340	202

Тормозные резисторы

Напря- жение	Модель преобразо- вателя	Легкая нагрузка			Тяжелая нагрузка			Тормозной преры- ватель
		Модель	Сопротив- ление, ОМ	Мощность рассеи- вания	Модель	Сопротив- ление, ОМ	Мощность рассеи- вания	
200 В	N700E-004SF/LF	RB-00P3-50	50,0	0,3	RB-00P3-50	50,0	0,3	Встроен
	N700E-007SF/LF							
	N700E-015SF/LF							
	N700E-022SF/LF	RB-00P3-50	50,0	0,3	RB-00P6-35	35,0	0,6	
	N700E-037LF	RB-00P6-35	35,0	0,6	RB-01P2-35	35,0	1,2	
	N700E-055LF	RB-01P0-17	17,0	1,0	RB-01P2-17	17,0	1,2	
	N700E-075LF							
	N700E-110LF							
	N700E-150LF	RB-02P5-8,7	8,7	2,5	RB-04P5-8.7	8,7	4,5	
	N700E-185LF	RB-03P0-6	6,0	3,0	RB-05P6-6	6,0	5,6	
N700E-220LF	RB-04P0-6	6,0	4,0	RB-06P6-6	6,0	6,6		
400 В	N700E-004HF	RB-00P3-180	180,0	0,3	RB-00P3-180	180,0	0,3	Встроен
	N700E-007HF							
	N700E-015HF							
	N700E-022HF	RB-00P3-100	100,0	0,3	RB-00P6-100	100,0	0,6	
	N700E-037HF	RB-00P6-100	100,0	0,6	RB-00P6-100	100,0	0,6	
	N700E-055HF	RB-01P2-70	70,0	1,2	RB-01P8-70	70,0	1,8	
	N700E-075HF	RB-01P2-50	50,0	1,2	RB-02P4-50	50,0	2,4	
	N700E-110HF	RB-02P0-50	50,0	2,0	RB-03P3-50	50,0	3,3	
	N700E-150HF	RB-02P5-30	30,0	2,5	RB-04P5-30	30,0	4,5	
	N700E-185HF	RB-03P0-20	20,0	3,0	RB-05P6-20	20,0	5,6	
	N700E-220HF	RB-04P0-20	20,0	4,0	RB-06P6-20	20,0	6,6	
	N700E-300HF	RB-05P0-12	12,0	5,0	RB-09P0-12	12,0	9,0	Опция
	N700E-370HF	RB-06P0-12	12,0	6,0	RB-11P2-12	12,0	11,2	
	N700E-450HF	RB-07P0-8	8,0	7,0	RB-13P5-8	8,0	13,5	
	N700E-550HF	RB-08P5-8	8,0	8,5	RB-16P5-8	8,0	16,5	
	N700E-750HF	RB-11 P2-6	6,0	11,2	RB-22P5-6	6,0	22,5	
	N700E-900HF	RB-11P2-6 (x2)	6,0 (x2)	11,2	RB-22P5-6 (x2)	6,0 (x2)	22,5	
	N700E-1100HF							
N700E-1320HF								
N700E-1600HF	RB-22P5-3 (x2)	3,0 (x2)	22,5	RB-45P0-3 (x2)	3	45,0		
N700E-2200HF								
N700E-2800HF								
N700E-3500HF	RB-33P7-2 (x2)	2,0 (x2)	33,7	RB-67P5-3 (x2)	2	67,5		

Аксессуары

Тормозные резисторы, габаритные размеры, мм

А Тип: RB-01P0 ~ RB-02P0

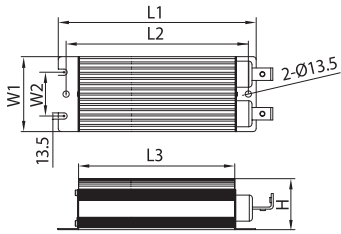

А Тип	L1	L2	L3	W1	W2	H
RB-01P0	340	385	302	70	39	45
RB-01P2	400	495	362			
RB-01P8 - RB-02P0	510		472			

В Тип: RB-02P4 ~ RB-22P5

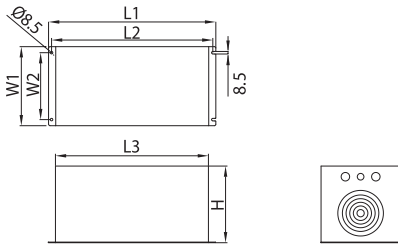

В Тип	L1	L2	L3	W1	W2	H
RB-02P4 ~ RB-01P2	550	530	503	180	140	126
RB-03P0				260	220	126
RB-04P0 ~ RB-05P6				180	140	182
RB-06P6				260	220	182
RB-08P0 ~ RB-09P0				260	220	252
RB-11P2 ~ RB-13P5						322
RB-16P5			392			
RB-22P5	340	300	392			

С Тип: RB-00P3

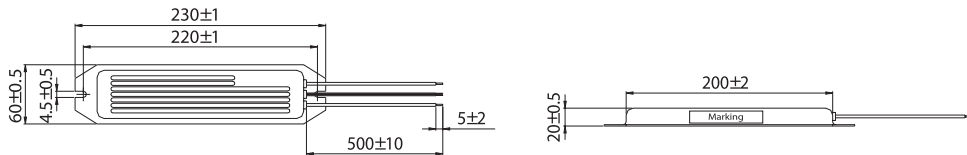

Д Тип: RB-00P6

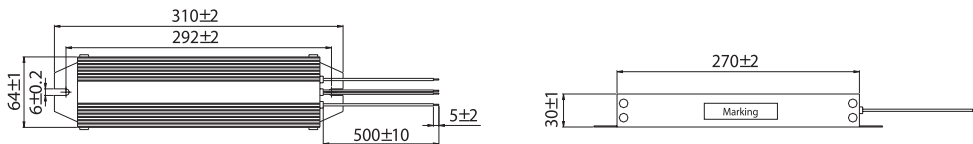

Е Тип: RB-01P2

