

Описание





- Часы с аналоговым дисплеем
- Минутные и часовые или секундные, минутные и часовые стрелки.
- ABS пластик, защита IP 40, IK 02
- Читаемость: 20 м.
- Полиэфирное волокно (PMMA).
- Цвета корпусов: чёрный, белый, алюминий, хром.
- Типы циферблата: Арабские цифры или минутные метки
- Настенный крепеж с дополнительной системой блокировки.

Стандарты

- Standard EN 50081-1: Generic Emissions.
- Standard EN 50082-1 and 50082-2: Generic Immunity.
- Standard EN 55022 class B: Information Technology Equipment – Radio disturbance characteristics.
- Standard EN 60950: Information Technology Equipment - Safety.
- Standard NFS 87-500 A: AFNOR and DHF Time Distribution Protocols.



Технические особенности

| | Синхронизация | Питание | Рабочие температуры | Вес |
|---|--------------------------------------|--|---------------------|--------|
|  | 24V minute parallel impulse | | - 10°C to +50°C | 0.9 kg |
|  | 24V second parallel impulse | | - 10°C to +50°C | 0.7 kg |
|  | ½ minute serial impulse | | - 10°C to +50°C | 0.9 kg |
|  | AFNOR | 6 to 24 VDC | - 5°C to +50°C | 0.7 kg |
|  | NTP NTP (silent, sweeping second) | Power over Ethernet, Class 0 device, 2W maximum | - 5°C to +50°C | 0.7 kg |

Ссылки

| Часы/мин | Часы/мин/сек 981 | |
|----------|------------------|-----------------|
| 981 5ху | 981 4ху | 24В мин.импульс |
| - | - | 24В сек.импульс |
| 981 6ху | 982 9ху | ½ мин |
| 982 8ху | 982 6ху | AFNOR |
| 982 Fху | 982 Nху | NTP |
| - | | NTP (тихие) |
| - | | |

Циферблаты (x):

- 1 = Араб. цифры 
- 2 = Метки часов 
- 3 = DIN 

Цвета корпуса (y):

- 1 = Белый 
- 2 = Черный 
- 5 = Серебристый 
- 3 = Хром (опц) 

Синхронизация

•24 В минут.импульс

Slave clocks are connected to a distribution line and activated through electrical impulses sent every minute by the master clock.

•24В секундный импульс

Slave clocks are connected to a distribution line and activated through electrical impulses sent every second by the master clock.

• 1/2 minute serial impulse

Slave clocks are connected to a distribution line and activated through electrical impulses sent every ½ minute by the master clock.

• AFNOR

The coded time distribution consists in transmitting a complete time message every second: the time on the receiver is automatically and immediately set after connection to the clock line.

The AFNOR coded time does not interfere with any other transmissions, and is insensitive to other electrical interference.

Consumption TBT: 10 mA (6 VDC), 8 mA (24 VDC).

• Network Time Protocol (NTP)

Slave clocks are connected to the Ethernet network and powered by PoE (Power over Ethernet).

The time is synchronised by the time server or the master clock over the Ethernet network in unicast, multicast or DHCP mode.

• Network Time Protocol (NTP) бесшумные

Slave clocks are connected to the Ethernet network and powered by PoE (Power over Ethernet).

The time is synchronised by the time server or the master clock over the Ethernet network in unicast, multicast or DHCP mode.

The second hand's movement is continuous. The advantage of this clock is its very low noise level (<20dB at 1 metre).

Односторонняя установка

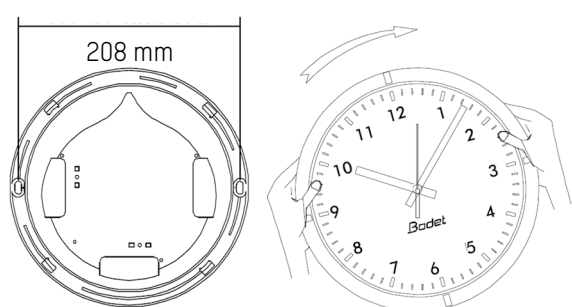

Двусторонняя установка

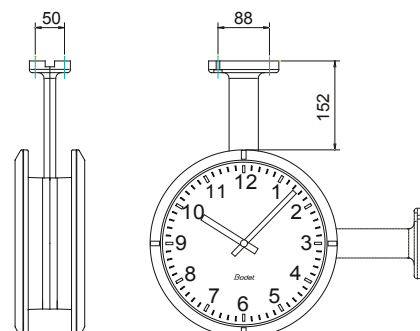

Аксессуары

- 981 001..... Крепеж для двусторонней установки
- 981 002..... Short double-sided bracket
- 981 006..... Secure wall mounting bracket for single-sided clock

- 938 914..... 230V recess mounting power supply for TBT clock
- 938 916..... 230V plug-in power supply for TBT clock

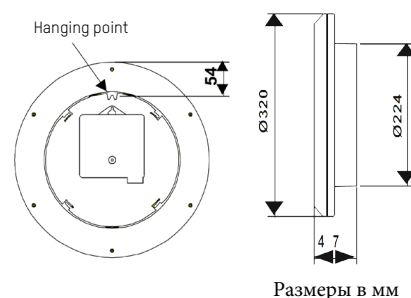

Размеры в мм